

# 755K

Crawler Loader



JOHN DEERE



# SPEC'D FOR YOUR SUCCESS

Inspired by invaluable input from owners and operators who've put our equipment through its paces, the 755K Crawler Loader provides the proven muscle and versatility you need to get the work done. This mid-size machine is loaded with productivity- and uptime-boosting features including choice of controls, smooth hydrostatics, no-sweat serviceability, and a spacious operator station packed with convenient creature comforts. And it's easy on fuel and your bottom line. Whether you're excavating, loading trucks, backfilling, or grading, the 755K Crawler Loader is designed to meet the most demanding specifications — yours.

## Comfort everywhere you look

Spacious cab features wide doorways and user-friendly pull-type latches to ease entry/exit from either side. Viscous cab mounts, rear acoustical glass, extensive insulation, and pressurization effectively isolate operators from vibration, noise, and dirt. Standard air conditioning and numerous directional vents keep the interior comfortable and tinted windows clear. Adjust the standard high-back air-suspension seat or deluxe heated and leather-bolstered seat for daylong comfort and support.

## Built to run long

Heavy-duty undercarriage is sealed and lubricated, for maximum wear resistance. Simple-to-navigate LCD monitor displays diagnostic messages and solutions to keep you up and running. Swing-out side shields and tilt-out grille enable access to both sides of the coolers, for low-effort debris removal. Hydrostatic and hydraulic pressures can be read on the in-cab monitor, easing system-pressure checks.

## Easy does it

Full-power turns, on-the-go counter-rotation, infinite speed control, and power management — state-of-the-art controls enable complete command of an arsenal of highly productive hydrostatic (HST) advantages. Choose joystick forward-neutral-reverse (F-N-R) or V-pattern transmission lever with steering pedals as well as single-lever joystick or two- or three-lever hydraulic controls to fit the operator's style.

## Waste not, want not

Standard Eco mode automatically adjusts engine power and transmission settings based on load while maintaining ground speed, to optimize fuel economy without sacrificing productivity. Auto-idle helps save fuel by reducing engine speed when the crawler loader isn't moving and no functions are being activated. To further help conserve fuel, auto shutdown automatically turns the engine off after an operator-determined period of inactivity.



**SMOOTH  
OPERATION**



**FUEL  
EFFICIENT**



DEERE

755K



### Peak performance

Low-effort controls command the full-featured HST drivetrain, providing smooth, predictable response at all times, in all conditions. Total Machine Control (TMC) enables customized operating characteristics and responses, for one-of-a-kind control. Just set maximum desired ground speed, and the power-management system automatically maintains peak engine rpm and power efficiency without stalling or shifting.

### On track in tight spaces

Constant power to both tracks allows heavy loads to be carried through turns and counter-rotations while in gear or neutral. Counter-rotating tracks boost maneuverability on crowded jobsites, a productivity advantage that also helps overcome heavy corner loads.

### Imagine the possibilities

Infinitely variable speed range to 6.2 mph enables travel to be adapted to fit specific tasks, terrain conditions, and operator preferences.

### Push-button easy

Control the throttle using buttons on the sealed-switch module — push the top button once to apply full throttle and the lower button once for low engine rpm. Press and hold either button for incremental adjustments.

### Within easy sight

Standard rearview camera with large LCD color display in the cab provides the operator with visibility to the ripper and rear of the crawler loader while still focusing on the jobsite ahead.

### Keep your cool

Quad-Cool™ places system components in a unique boxed configuration that's isolated from engine heat, boosting efficiency and durability.



## 755K CRAWLER LOADER



+



MANEUVERABLE

VERSATILE



### The choice is yours

Choose between a general-purpose or a multipurpose bucket to best fit the application.

### Precision Construction

From grade management and obstacle detection to product automation features and jobsite intelligence, this suite of construction technology delivers productivity solutions to help you get more done, more efficiently.

John Deere construction equipment comes with in-base connectivity — free from subscriptions or annual renewals. Analyze critical machine data, track utilization, review diagnostic alerts, and more from **the John Deere Operations Center™**. The Operations Center also enables **John Deere Connected Support™**, which uses data from thousands of connected machines to proactively address issues before they arise. Your dealer can also remotely monitor machine health, diagnose problems, and even update machine software without a trip to the jobsite.\*

\*Availability varies by region and product. Options not available in every country.



# 755K CRAWLER LOADER SPECIFICATIONS

<b>Engine</b>		<b>755K</b>	
Manufacturer and Model	John Deere PowerTech™ PVS 6068		
Non-Road Emission Standard	EPA Final Tier 4/EU Stage IV		
Displacement	6.8 L (414 cu. in.)		
SAE Net Rated Power	145 kW (194 hp) at 1,800 rpm		
Net Peak Torque	942 Nm (695 ft.-lb.) at 1,400 rpm		
Aspiration	Turbocharged with charge-air cooler		
Air Cleaner	Dual-stage dry tube with tangential unloader		
<b>Cooling</b>			
Fan	Variable-speed suction fan with automatic reversing		
Engine Coolant Rating	-37 deg. C (-34 deg. F)		
Engine Radiator	10.2 fins per inch		
<b>Powertrain</b>			
<b>Transmission</b>	Automatic, dual-path, hydrostatic (HST) drive; load-sensing feature automatically adjusts speed and power to match changing load conditions; each individually controlled track is powered by a variable-displacement piston pump and motor combination; ground-speed selection buttons on single-lever steering and direction control; independently selectable reverse speed ratios of 100%, 115%, or 130% of forward ground speed; decelerator pedal controls ground speed to stop		
System Relief Pressure	45 850 kPa (6,650 psi)		
Travel Speeds			
Forward and Reverse	10 km/h (6.2 mph)		
Maximum (optional)	10 km/h (6.2 mph)		
<b>Steering</b>	Single-lever steering, speed, direction control, and counter-rotation; full power turns and infinitely variable track speeds provide unlimited maneuverability and optimum control; HST steering eliminates steering clutches and brakes		
<b>Final Drives</b>	Double-reduction, planetary final drives transfer torque loads over 3 gear sets		
Total Ratio	44.7483 to 1		
<b>Drawbar Pull</b>			
Maximum	345 kN (77,600 lb.)		
At 1.9 km/h (1.2 mph)	173 kN (39,000 lb.)		
At 3.2 km/h (2.0 mph)	118 kN (26,600 lb.)		
<b>Brakes</b>	Decelerator/brake pedal; automatic power management with manual override for matching ground speed to available engine power		
<b>Service Brakes</b>	HST (dynamic) braking stops the machine whenever the direction-control lever is moved to neutral or whenever the decelerator is depressed to the end of travel		
Type	Hydraulic		
<b>Parking Brakes</b>	Exclusive safety feature engages wet, multiple-disc brakes whenever the engine stops, whenever the decelerator is depressed to the end of travel, or whenever the park-lock lever is placed in the upward position or the transmission-control lever is placed in the neutral position and motion is detected; machine cannot be driven with brake applied, reducing wear-out or need for adjustment; spring-applied, hydraulic release		
<b>Hydraulics</b>			
Type	Load sense, piston pump		
Pump Flow	246 L/m (65 gpm)		
System Relief Pressure	26 028 kPa (3,775 psi)		
Differential Pressure	1896 kPa (275 psi)		
Maximum Flow at Unloaded High Idle	256 L/m (68 gpm)		
Control	Dual-axis joystick with optional multipurpose bucket function, or 2- or 3-lever stackable		
<b>Cylinders</b>			
Heat-treated, chrome-plated, polished cylinder rods; hardened steel pivot pins with replaceable bushings			
	<i>Bore</i>	<i>Rod Diameter</i>	<i>Stroke</i>
<b>Lift Cylinders</b>	140 mm (5.5 in.)	80 mm (3.1 in.)	854 mm (33.6 in.)
<b>Bucket-Dump Cylinder</b>	180 mm (7.0 in.)	115 mm (4.5 in.)	551 mm (21.7 in.)

While general information, pictures, and descriptions are provided, some illustrations and text may include product options and accessories NOT AVAILABLE in all regions, and in some countries products and accessories may require modifications or additions to ensure compliance with the local regulations of those countries.

<b>Electrical</b>		<b>755K</b>				
Voltage	24 volts					
Number of Batteries (12 volt)	2					
Battery Capacity	950 CCA					
Reserve Capacity	190 min.					
Alternator Rating	100 amp					
Lights	Halogen cab-mounted forward facing (2), rear mounted (2), and engine compartment (1)					
<b>Undercarriage</b>						
<b>Tracks</b>	Track frame with front and rear track guides and sprocket guards; John Deere undercarriage features deep-heat-treated, sealed, and lubricated track links and through-hardened, sealed, and lubricated rollers for maximum wear resistance; sprockets are segmented					
Track Gauge	1880 mm (74 in.)					
Grouser Width	560 mm (22 in.)					
Chain	Sealed and lubricated					
Shoes, Each Side	38					
Track Rollers, Each Side	6					
Track Length on Ground	2588 mm (102 in.)					
Ground Contact Area						
510-mm (20 in.) Grouser Width	26 294 cm <sup>2</sup> (4,076 sq. in.)					
560-mm (22 in.) Grouser Width	28 985 cm <sup>2</sup> (4,493 sq. in.)					
Ground Pressure	<i>General-Purpose Bucket</i>		<i>Multipurpose Bucket</i>			
510-mm (20 in.) Grouser Width	76.5 kPa (11.1 psi)		77.2 kPa (11.2 psi)			
560-mm (22 in.) Grouser Width	69.6 kPa (10.1 psi)		70.3 kPa (10.2 psi)			
Track Pitch	203 mm (8 in.)					
Oscillation at Front Roller	±35 mm (±1.4 in.)					
<b>Buckets (with teeth)</b>						
	<i>Width</i>	<i>Capacity Heaped</i>	<i>Bucket Weight</i>	<i>Breakout Force</i>	<i>Static Tipping Load</i>	<i>Maximum Clamping Force</i>
<b>General Purpose</b>	2591 mm (130 in.) (8 ft. 6 in.)	2.5 m <sup>3</sup> (3.2 cu. yd.)	1544 kg (3,404 lb.)	197 kN (44,287 lbf)	15 362 kg (33,867 lb.)	N/A
<b>Multipurpose</b>	2591 mm (130 in.) (8 ft. 6 in.)	2.0 m <sup>3</sup> (2.6 cu. yd.)	1830 kg (4,035 lb.)	197 kN (44,287 lbf)	14 901 kg (32,851 lb.)	11 110 kg (24,493 lbf)
<b>Operator Station</b>						
ROPS (ISO 3471 – 2008)						
<b>Serviceability</b>						
<b>Refill Capacities</b>						
Fuel Tank With Lockable Cap	326 L (86.0 gal.)					
Cooling System With Recovery Tank	32 L (8.5 gal.)					
Engine Oil With Filter	24.6 L (6.5 gal.)					
Transmission Reservoir With Filter	66.6 L (17.6 gal.)					
Hydraulic Reservoir and Filter	103.0 L (27.2 gal.)					
Diesel Exhaust Fluid (DEF) Reservoir	8.5 L (2.2 gal.)					
Final Drive						
Inner Final Drive (each)	8.0 L (2.1 gal.)					
Outer Planetary (each)	15.6 L (4.1 gal.)					

While general information, pictures, and descriptions are provided, some illustrations and text may include product options and accessories NOT AVAILABLE in all regions, and in some countries products and accessories may require modifications or additions to ensure compliance with the local regulations of those countries.

# 755K CRAWLER LOADER SPECIFICATIONS (continued)

Operating Weights		755K
<i>With standard equipment, cab with pressurizer and heater/air conditioner, general-purpose bucket with bolt-on teeth and edge segments, full fuel tank, and 79-kg (175 lb.) operator</i>		
Base Weight	20 492 kg (45,178 lb.)	
Optional Components		
Cab With Pressurizer and Heater/ Air Conditioner	In base	
Lift-Cylinder Guards	25 kg (55 lb.)	
Full-Length Rock Guards	218 kg (480 lb.)	
Final-Drive Trash Guards	70 kg (155 lb.)	
Clam-Cylinder Protection for Multi- purpose Bucket	50 kg (110 lb.)	
Retrieval Hitch	67 kg (147 lb.)	
Double-Bar Grousers		
510 mm (20 in.)	-141 kg (-311 lb.)	
560 mm (22 in.)	In base	
Machine Dimensions		
A Overall Height	3330 mm (10 ft. 11 in.)	
B Tread Depth With Double-Bar Grouser	42.5 mm (1.7 in.)	
C Length to Front of Track	5157 mm (16 ft. 11 in.)	
D Overall Length With Bucket and Teeth		
General Purpose	6824 mm (269 in.) (22 ft. 4.6 in.)	
Multipurpose	6824 mm (269 in.) (22 ft. 4.6 in.)	
E Track Gauge	1880 mm (6 ft. 2 in.)	
F Ground Clearance (excludes grouser height)	432 mm (17 in.)	

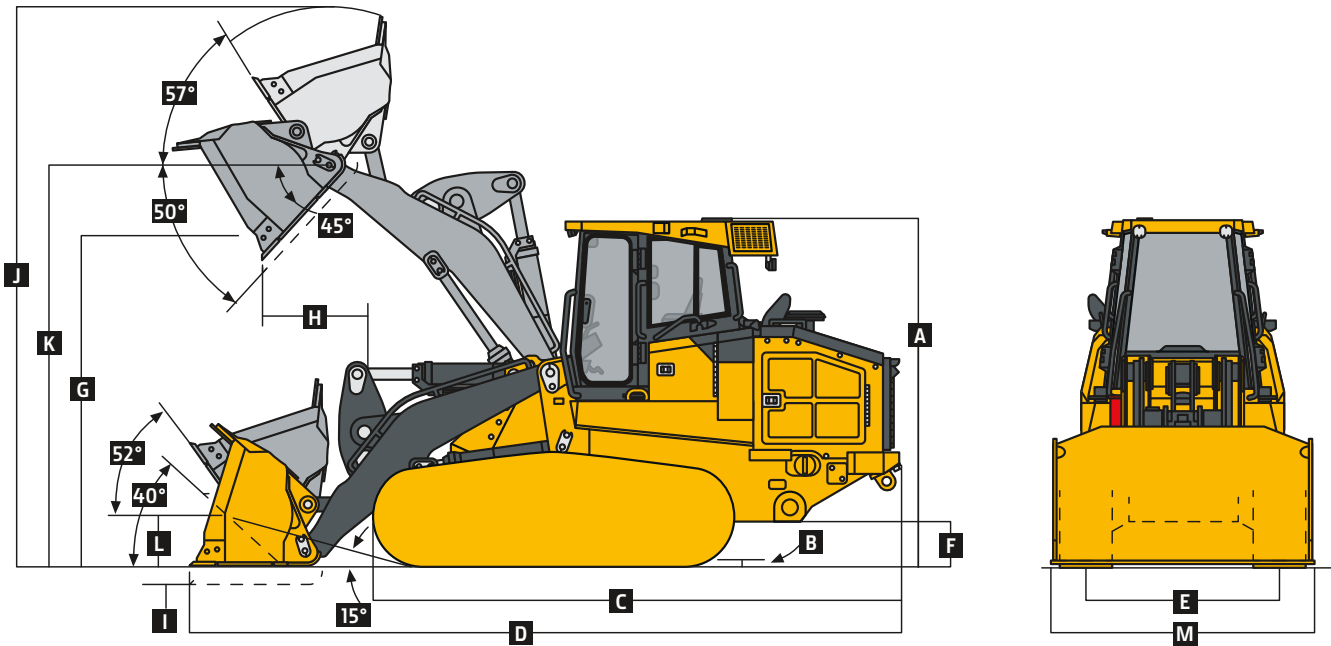

755K CRAWLER LOADER WITH GENERAL-PURPOSE BUCKET

While general information, pictures, and descriptions are provided, some illustrations and text may include product options and accessories NOT AVAILABLE in all regions, and in some countries products and accessories may require modifications or additions to ensure compliance with the local regulations of those countries.



Machine Dimensions (continued)	755K
<b>Bucket Type</b>	General-Purpose Bucket
<b>G</b> Dumping Height at 45 deg.	2950 mm (116 in.)
<b>H</b> Reach at 45 deg.	1100 mm (43 in.)
<b>I</b> Maximum Digging Depth Below Grade	167 mm (6.6 in.)
<b>J</b> Maximum Operating Height	5592 mm (220 in.)
<b>K</b> Maximum Height of Hinge Pin	4080 mm (160.6 in.)
<b>L</b> Height of Hinge Pin, Transport	457 mm (18 in.)
<b>M</b> Width of Bucket	2591 mm (102 in.)

Machine Dimensions (continued)	755K
<b>Bucket Type</b>	Multipurpose Bucket
<b>G</b> Dumping Height at 45 deg. (bucket)	2959 mm (116.5 in.)
<b>G'</b> Dumping Height at 45 deg. (blade)	3662 mm (144 in.)
<b>H</b> Reach at 45 deg. (bucket)	1009 mm (39.7 in.)
<b>H'</b> Reach at 45 deg. (blade)	406 mm (16 in.)
<b>I</b> Maximum Digging Depth Below Grade	226 mm (8.9 in.)
<b>J</b> Maximum Operating Height (open)	5447 mm (215.5 in.)
<b>J'</b> Maximum Operating Height (closed)	6223 mm (245 in.)
<b>K</b> Maximum Height of Hinge Pin	4080 mm (160.6 in.)
<b>L</b> Height of Hinge Pin, Transport	457 mm (18 in.)
<b>M</b> Width of Bucket	2591 mm (102 in.)
<b>N</b> Width of Opening	1239 mm (48.8 in.)

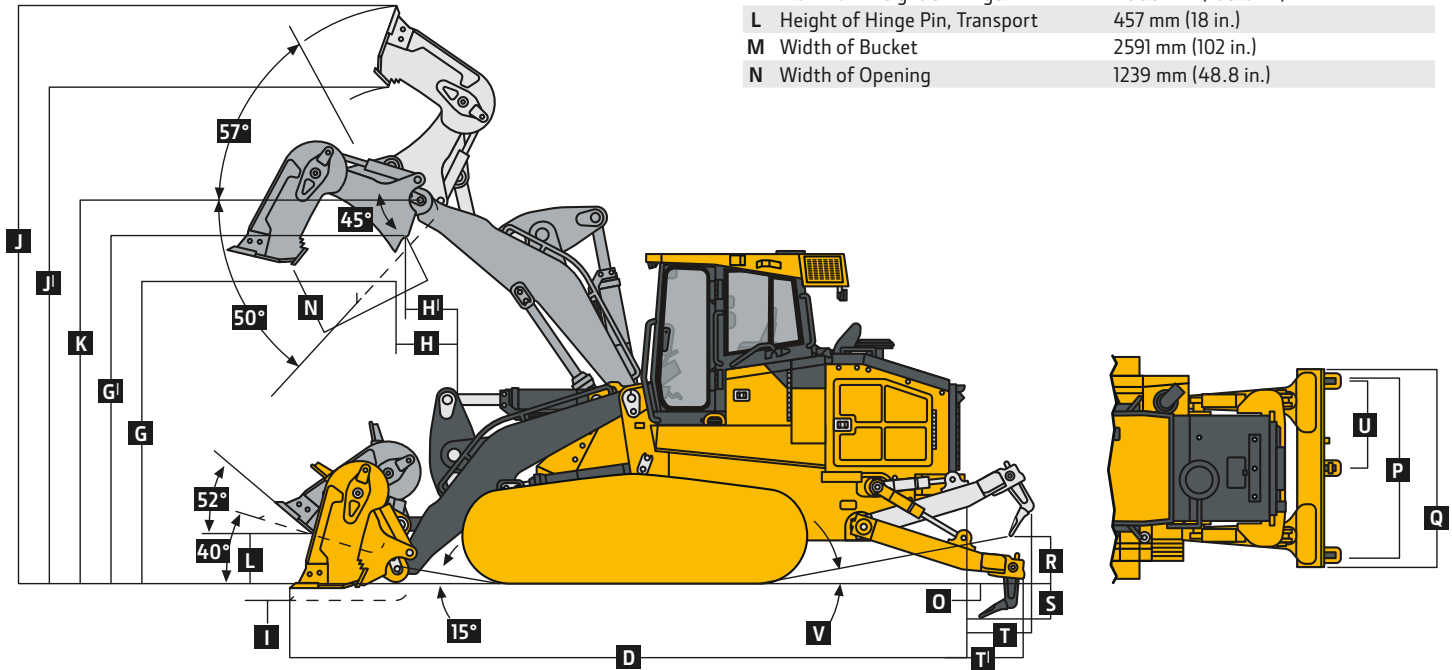

755K CRAWLER LOADER WITH MULTIPURPOSE BUCKET AND 3-SHANK RIGID-TYPE RADIAL RIPPER WITH ESCO® RIPPER TIPS

Rear Ripper	755K
Multi-shank (3) radial ripper with ESCO ripper tips	
Ripper Weight	884 kg (1,950 lb.)
<b>O</b> Ground Clearance Below Toolbar	166 mm (6.5 in.)
<b>P</b> Ripping Width	1880 mm (6 ft. 2 in.)
<b>Q</b> Toolbar Width	2118 mm (83.4 in.)
<b>R</b> Lifting Height	800 mm (31.5 in.)
<b>S</b> Ripping Depth	254 mm (10 in.)
<b>T</b> Additional Overall Length, Raised	608 mm (24 in.)
<b>T'</b> Additional Overall Length, Lowered	604 mm (23.8 in.)
<b>U</b> Distance Between Teeth	940 mm (3 ft. 1 in.)
<b>V</b> Approach Angle, Ripper Raised	17 deg.

While general information, pictures, and descriptions are provided, some illustrations and text may include product options and accessories NOT AVAILABLE in all regions, and in some countries products and accessories may require modifications or additions to ensure compliance with the local regulations of those countries.

# Additional equipment

Key: ● Standard ▲ Optional or special See your John Deere dealer for further information.

## 755K Engine

- Meets EPA Final Tier 4/EU Stage IV emissions
- Electronic control with automatic engine protection
- Programmable auto engine shutdown
- Dual-element dry-tube air cleaner with tangential unloader valve
- Environmental service drains
- Engine glow plug starting system
- Auto turbo cool-down timer
- Wet-sleeve cylinder liners
- Eco mode
- Automatic, on-the-fly exhaust filter cleaning
- Fuel filters with automatic electronic priming
- 100-amp alternator
- ▲ 120-volt engine block heater
- ▲ Severe-duty 400-mL fuel filter and water separator
- ▲ Rotary ejector engine air precleaner

## Cooling

- Tilt-out cooling fan, hydraulically driven, variable-speed suction type
- ▲ Automatic, programmable reversing fan
- Engine coolant radiator (10.2 fins per in.)
- Hydrostatic cooler (oil/air – 10.2 fins per in.)
- Hydraulic cooler (oil/air – 10.2 fins per in.)
- Enclosed safety fan guard (conforms to SAE J1308 and ISO3457)
- Perforated engine and hood side shields
- Heavy-duty, trash-resistant radiator and high-ambient cooling package
- Tilt-out bar-type grille
- Extreme-duty grille

## Transmission

- Automatic transmission derating for exceeded system temperatures
- Diagnostic test ports
- Environmental service drains
- 2,000-hour vertical spin-on transmission filter

## 755K Transmission (continued)

- Sealed dedicated transmission reservoir and filtration system separate from hydraulic system
- Single-lever joystick direction, speed, and steering control
- ▲ V-pattern direction and speed control with pedal steering
- ▲ Final-drive seal guards (for trash use)

## Hydraulic System

- 2-function hydraulics – joystick or dual lever
- ▲ 3-function hydraulics – joystick or 3 lever
- ▲ Rear hydraulics with rear plumbing
- Sealed dedicated hydraulic reservoir and filtration system separate from transmission system
- 2,000-hour vertical spin-on hydraulic filter

## Mainframe, Access Panels

- Tilt operator station service access
- Integral bottom protection
- Hinged bottom-access covers (bolt-on)
- Vandal protection: Engine access door / Side tank access doors / Fuel tank / Instrument panel / Transmission reservoir / Hydraulic reservoir
- Maintenance-free center crossbar pivot

## Loader

- Return-to-dig feature
- Bucket-level indicator
- Bucket float
- Boom height-control feature
- Integrated front tow hook
- Loader boom service lock

## Undercarriage

- Oscillating undercarriage with remote lube bank
- Full-length, smooth-surface track frame covers
- Guides, front and rear, with bolt-on wear strips
- Segmented sprockets
- Double-flange rollers

While general information, pictures, and descriptions are provided, some illustrations and text may include product options and accessories NOT AVAILABLE in all regions, and in some countries products and accessories may require modifications or additions to ensure compliance with the local regulations of those countries.

Net engine power is with standard equipment including air cleaner, exhaust system, alternator, and cooling fan at test conditions specified per ISO9249. No derating is required up to 3050-m (10,000 ft.) altitude. Specifications and design subject to change without notice. Wherever applicable, specifications are in accordance with SAE standards. Except where otherwise noted, these specifications are based on units with rollover protective structures (ROPS), full fuel tanks, 79-kg (175-lb.) operators, and standard equipment.

# Additional equipment *(continued)*

Key: ● Standard ▲ Optional or special See your John Deere dealer for further information.

## 755K Undercarriage *(continued)*

- ▲ Final-drive seal trash guards
- ▲ Extended-life undercarriage with SC-2™ bushings
- Heavy-duty sealed and lubricated undercarriage
- ▲ Full-length rock guards
- 560-mm (22 in.) closed-center double-bar grousers
- ▲ 510-mm (20 in.) closed-center double-bar grousers
- ▲ 510-mm (20 in.) open-center double-bar grousers with trapezoidal holes
- ▲ 560-mm (22 in.) open-center double-bar grousers with trapezoidal holes

## Attachments

- ▲ 2.5-m<sup>3</sup> (3.2 cu. yd.) general-purpose bucket
- ▲ 2.0-m<sup>3</sup> (2.6 cu. yd.) multipurpose bucket
- ▲ Bolt-on cutting edges
- ▲ Bolt-on bucket teeth
- ▲ Bolt-on edge segments and teeth
- ▲ Bolt-on rear hitch hoop
- ▲ Radial rear ripper, 3 shank
- ▲ Operator-protection package
- ▲ Tilt cylinder protection
- ▲ Lift cylinder line protection
- ▲ Multipurpose bucket cylinder protection
- ▲ Waste-handler package
- ▲ Limb risers
- ▲ Cab screens

## Operator's Station / Electrical

- Electronic monitoring system with audible and visual warnings for engine oil temperature, engine oil pressure, hydraulic oil temperature, transmission oil temperature, and transmission charge pressure
- Built-in diagnostics – Diagnostic-code details, sensor values, calibrations, and individual circuit tester

## 755K Operator's Station / Electrical *(continued)*

- Multifunction/multi-language LCD monitor – Analog display (fuel level, coolant temperature, engine oil pressure, and voltage) and digital display (engine rpm, charge pressure, hours, diesel particulate filter [DPF] soot level and transmission direction/speed range)
- Retractable seat belt, 76 mm (3 in.) (conforms to SAE J386)
- Convex interior rearview mirror (conforms to SAE J985)
- 12-volt power port
- ▲ 2nd console-mounted power port, 12 volts
- Air conditioner, 24,000 Btu
- Tinted glass
- Dome light
- Heater (roof mount)
- Air-ride fabric seat
- ▲ Deluxe heated and leather-bolstered air-ride seat
- Under-seat heater
- Wipers (intermittent plus 2 speeds) and washers – front and rear windows
- AM/FM/Weather-Band (WB) radio and clock
- Rearview camera with dedicated color monitor
- Lockable master electrical disconnect switch
- Keyless start with multiple security modes
- Lights, roof mounted (2) front, rear mounted (2)
- Engine compartment light
- ▲ Work lights, roof mounted (2) additional front
- JDLink™ wireless communication system (available in specific countries; see your dealer for details)
- ▲ Fast-fuel system
- ▲ Fluid-sample ports (engine oil, coolant, and hydraulic and hydrostatic oil)
- ▲ Quick-service ports (engine oil, coolant, and hydraulic and hydrostatic oil)
- ▲ Polycarbonate front windshield

While general information, pictures, and descriptions are provided, some illustrations and text may include product options and accessories NOT AVAILABLE in all regions, and in some countries products and accessories may require modifications or additions to ensure compliance with the local regulations of those countries.

Net engine power is with standard equipment including air cleaner, exhaust system, alternator, and cooling fan at test conditions specified per ISO9249. No derating is required up to 3050-m (10,000 ft.) altitude. Specifications and design subject to change without notice. Wherever applicable, specifications are in accordance with SAE standards. Except where otherwise noted, these specifications are based on units with rollover protective structures (ROPS), full fuel tanks, 79-kg (175-lb.) operators, and standard equipment.



DKAKRLDR755 (23-09)



**JOHN DEERE**