

# CH570 Cane Harvester



## Delivering Innovative Products of Superior Quality, Built on a Tradition of Integrity Since 1837

John Deere, a world leader in providing advanced products and services, is profoundly committed to the success of customers whose work is linked to the land - those who cultivate, harvest, transform, enrich and build upon the land to meet the world's dramatically increasing need for food, fuel, shelter and infrastructure.

With feet on the ground and eyes on the horizon our deep customer understanding has guided us into reengineering the well-know 3520 to deliver a distinctive John Deere experience.

The all-new CH570 harvester with its outstanding comfort and innovative cane handling system will provide better returns for your operation by increasing the amount and quality of cane delivered from your field during the whole life cycle of your crop at a reduced cost.

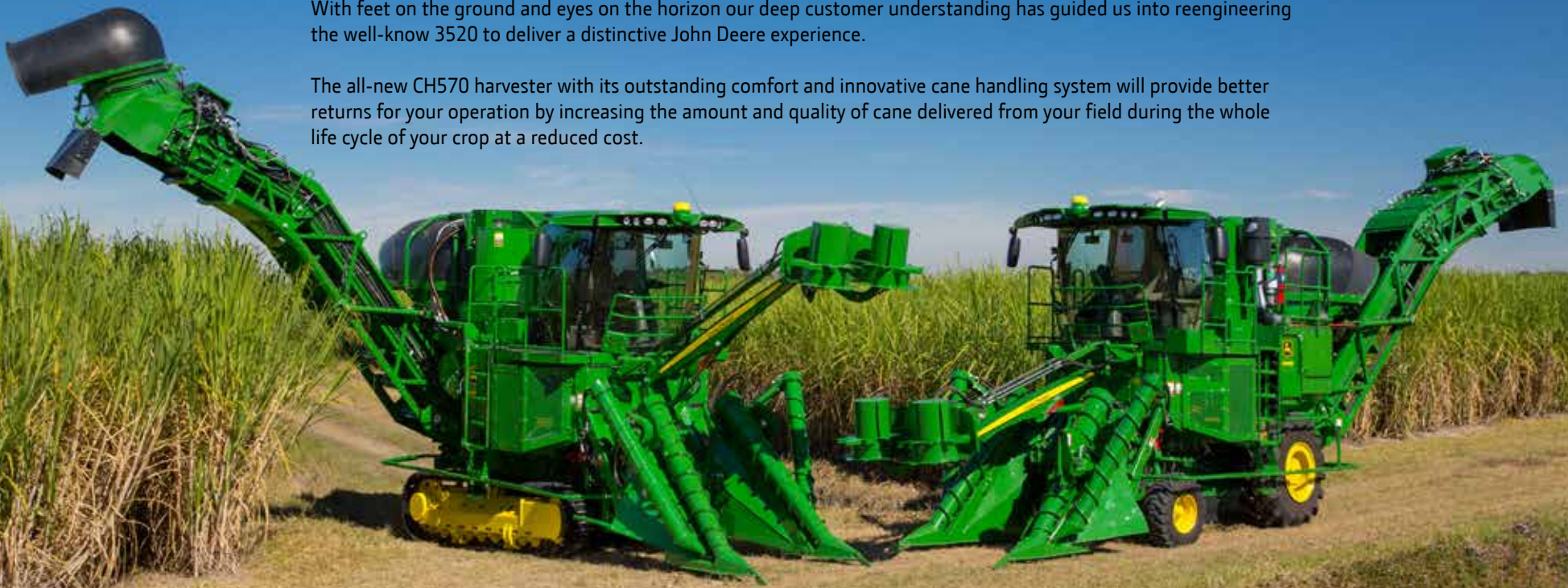

## Highest Reaching Topper

The unmatched 5.2 m (17ft) topper reach with a strong boom design and a cushion accumulator allows topping of the tallest cane.

New piston motor replaces the gear type for higher torque and efficiency.



The collecting drums of the standard whole topper efficiently gather the tops before they are cut.



Extensions can be added to guide leaves into the topper's cutting blades more effectively. It also works well where flowering sugar cane is prevalent.



Adopted as an option from the CH670 the extended width whole topper will reach tops and leaves that spread out farther away from the row.



The optional shredder topper facilitates residue management.

## New Front End

The crop dividers, side knives, knock down rollers and floating sidewalls were redesigned for a smooth uniform feed reducing cane losses and soil content.

The outside scrolls are now standard so that your unit is always prepared for different circumstances in your farm. The length of the scrolls was increased so the separation of lodged tangled cane begins closer to the ground.

The inside scrolls were angled towards the inside in order to improve feeding in heavy cane and as a result the crop divider knock down rollers are no longer needed.

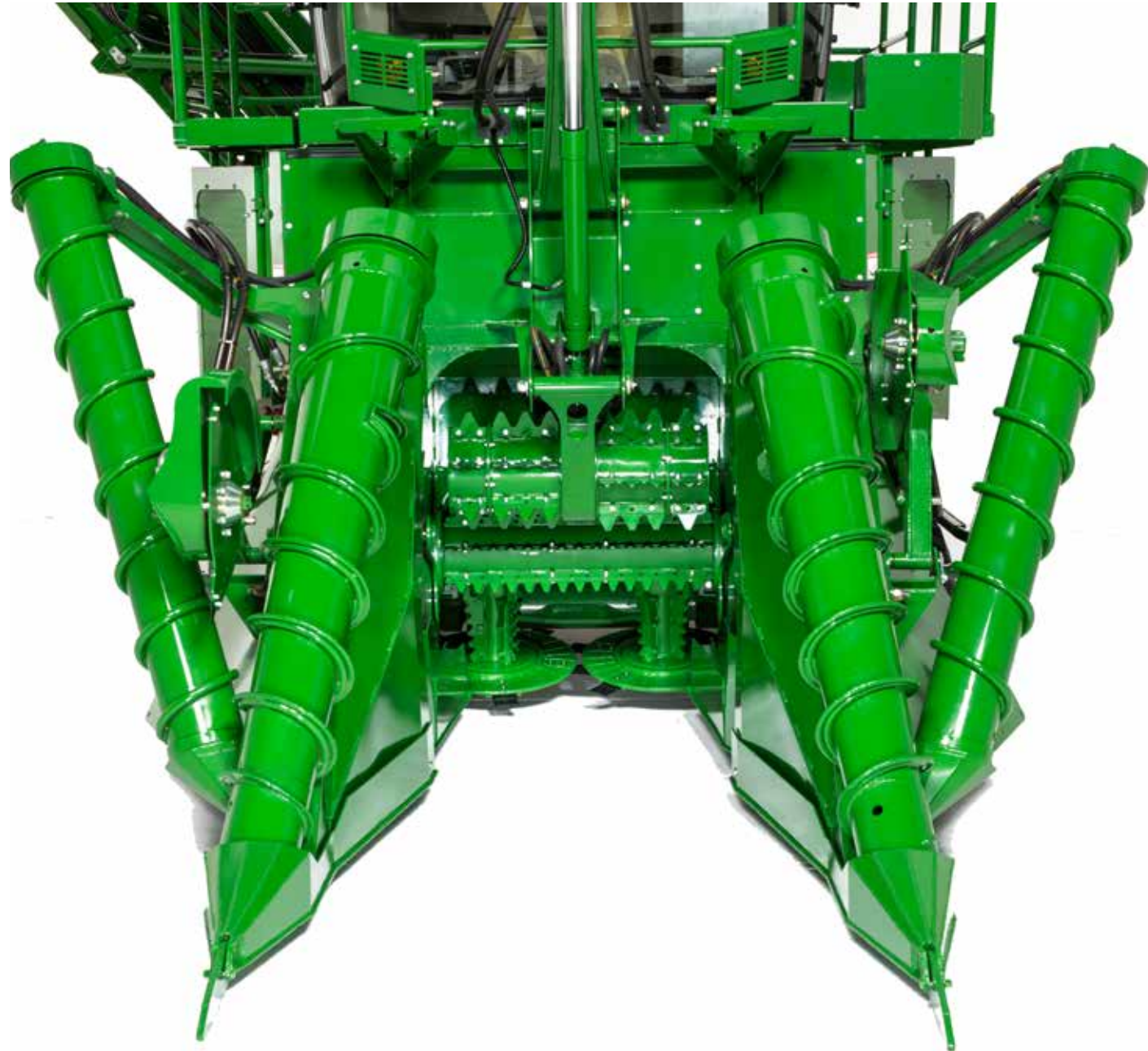

## Adjustable Side Knives



The height is now adjustable to quickly adapt to all possible cane conditions from the cab.



The geometry of the optional side knives has been restyled for a gentler cut, while allowing cane to flow freely when not in use.



## Synchronized Rollers & Self-Adjusting Sidewalls

Overall diameters of the knockdown rollers were increased for better gripping and the front roller reach was extended to start feeding the cane earlier when needed. The lower roller length has been increased to eliminate the dead spots near the walls.



Add the innovative hydraulic tilt to your machine and the rollers will align simultaneously so that both maintain contact with the cane, improving feeding and minimizing breakage especially with brittle varieties.



New heavy duty chainless floating sidewall maintain the proper height to reduce cane losses and risk of damage during operation or maneuvering.

## Benchmark for Base Cutting

The basecutter is a center driven design with just four gears to balance the load and reduce wear, powered by a hydraulic piston motor. Two large discs equipped with five easily replaceable blades ensure a clean cut with minimum stubble damage.

The standard 337 HP engine option has the basecutter and chopper on one high-pressure hydrostatic circuit driven by a powerful piston pump maximizing efficiency. The 375 HP option includes an additional piston pump so that the basecutter and chopper are on two independent circuits increasing the capacity to process the heaviest cane.



Standard large 61 cm (24 in) diameter discs or optional 56 cm (22 in) are available.



Open buttlifter options minimize soil intake and mud build-up



## Improved Feedroller System & New Modular Chopper

Feeding into the chopper has been optimized by reshaping lower feedrollers so that the cane is spread out across the entire width improving billet length consistency, cane quality and density.

The New modular chopper assembly is independent from the harvester main frame for a better fit and easier service. It sits on rubber mounts to absorb vibrations.

The chopping area is larger with New longer blades and contact is even through the whole length.

You can expect: simpler service, longer component life, uniform higher quality billets, and better feeding into the primary cleaning chamber.



Select from six, eight or ten blade chopper options for your billet length needs. Overlap chopper is also available with eight or ten blades.



Improved Feedroller System



New Modular Chopper

## Optimized Primary Extractor

The primary extractor optimization starts with a wider and better distributed cane mat being fed from the New chopper. This allows for more cane surface to be in contact with the air flow for better trash separation.

The New conical hub cover reduces air voids and recirculation while the wide-design blade produces more airflow at lower RPM. The New hard-surfaced blades combined with operating at much lower speed results in significantly longer blade life.

The motor drive support system features four rubber-mounted legs to improve fan stability and reduce vibrations. The fan is mounted directly to the motor shaft, which means no bearings, no blade balancing, less vibration, and less components, and since the motor is internally mounted it is not necessary to remove it for transport.

The optional duraliner steel will prolong the life of the wear ring.



The four-blade, 152 cm (5 ft) diameter fan is the largest in the industry.



The secondary extractor completes the cleaning and with its 360 degree hood rotation, directs the trash away from the wagon in the desired direction.





## Robust High Capacity Elevator

The CH570 features a high capacity structural tube frame elevator for extended durability. The top and bottom idler sprockets reduce wear and prolong the elevator chain life.

The tall side walls and reversible slats will handle the heaviest cane keeping billets from “boiling down” and with the hydraulically adjustable flap the operator can load the wagon evenly.

The elevator hoses are routed inside the solid frame promoting longer life by improving protection and minimizing exposure. Grease cylinder facilitates easy chain tension adjustment.

Elevator extension options are available to adapt to different row spacing.



Exclusive tall reversible slats and perforated floor for cleaning cane.



Heavy duty elevator swing table designed to withstand the heaviest loads and toughest field conditions. Exclusive wiper is standard.



Optional elevator speed control. Chain speed can be set from the CommandCenter to prolong the life of the chain and other wear items

## All New Roomier Cab



The New premium smart cab is 30% more spacious and offers all the necessary comfort, convenience and intelligent features operators will ever need.

Reduced noise levels plus improved air conditioning cooling with overhead vents will keep you relaxed during the long working hours.

180-degree view lets you see past the horizon on just about every side of you and with the greater lighting power you can operate at night with minimum difference from day time.

You can access the cab conveniently from the right or from the left.





## Premium Operator Experience

User-friendly, and quick to locate, the New CommandARM™ is home to every operating feature you'll need for a simple yet productive day. That includes hot keys for all of your common harvesting adjustments as well as your air conditioning, radio, and lighting controls.

The New multi-function control lever fits your hand comfortably to give smooth hydrostatic speed control. It also controls most harvesting functions. Three programmable buttons are included to customize harvester functions to operator preferences.

Our New 2630 GS 3 CommandCenter™ 25 cm (10") display puts vital machine and harvesting information within easy reach and with touch screen technology it is simple to make quick adjustments.





The air suspension seat has multiple adjustments and swivels so you can find the perfect fit and viewing angle.



Alerts, engine speed, power meter, and other harvesting performance checks ... are all well-lit and easy-to-read for your convenience on the perfectly-placed digital Cornerpost display.



No longer on the floor, the elevator swing is easily controlled from the multi-function control lever. One extra click and the elevator will swing 90°.



On the Harvester Activity Monitor screen you can identify areas of inefficiencies and take corrective actions that will reduce logistics cost.



Adjust the double-tilt telescopic steering column to your driving preferences. Also road controls are now located on the steering column.



"Smart Mode" is available to automatically reduce extractor speed to a preset minimum when the elevator is off.



Eight lights are now used including four high luminosity type that will greatly facilitate night operation. For optimum brightness on the wagon add the optional LED auxiliary lights.



The integrated refrigerator will keep your refreshments cold all day.

## John Deere Innovative Technologies



AutoTrac™ \*, John Deere hands-free steering technology is available for the CH570 through your local dealer. This system helps to maximize productivity, reduce operator strain, decrease stubble damage, and prevent row crossing in heavy lodged cane. It is especially useful for keeping the harvester centered on the row during night time operation and when opening a field.

The CH570 is also JDLink™\* capable, so in areas where the system is available you can contact your dealer for the additional components, accessories and subscription needed to take full advantage of John Deere technology. You can boost productivity and maximize uptime with JDLink remote machine monitoring. The system will send machine information over cellular connection and make it available on the JDLink website. With JDLink you can remotely monitor equipment health, transfer data to and from the machine, stay informed on the next maintenance schedule and remotely access information such as engine hours, location and fuel consumption. You can also protect your equipment against misuse and theft with curfew, geofencing and much more.

\*Activation/subscription required. Some additional accessories and/or components may be required. JDLink requires a cellular data connection to transfer information from machine to JDLink website. Consult your local John Deere Dealer for coverage availability and subscription information..

## Contour Basecutter Height Control & Floating Crop Dividers



The unique Floating Crop Divider\*\* technology was not only inherited to the CH570 but also enhanced with a Newly designed linkage system. The floating crop dividers follow the ground profile without plowing while constantly keeping the toe under lodged cane. The benefits are lower soil content, reduced cane loss, and minimum soil disturbance.

We also increased the precision of our exclusive Contour Basecutter Height Control\*\* with the addition of a pressure signal to the existing position input. The system ensures that cane is cut at the desired height resulting in higher yield (tons of sugar/ha), cleaner cane, and healthier stubble for improved future crops.

With End of Row and Return to Cut technology the harvester and crop dividers rise simultaneously with a single button when exiting the field and upon entering the next row the unit returns to the predefined cutting height setting.

\*\*Optional features

## Powerful Performance Around the World

Developed specifically for agricultural applications the proven John Deere 24 Valve PowerTech, 9 Liter engine is available in different emission certification levels at 337 or 375 horsepower ratings to satisfy requirements for any country.

The true test of strength is not what the harvester can do at rated engine power, but what it can do above it. When you lug down this harvester, it develops as much as 14% power bulge. This extra muscle is what truly keeps it harvesting efficiently through the heaviest canes in the world.

The reliability of the CH570 engine has been improved with a higher capacity suction control valve and top of the line injectors and piston rings. In addition all filters are now located remotely to facilitate servicing.



With the New Auto FieldCruise™ the engine speed adjusts to the load automatically. When harvesting light cane or other low load condition, the Engine RPM will decrease to save fuel. This can also increase engine and hydraulic components life depending on field conditions and operating practices.



Reliable John Deere PowerTech™ engine with remote filters



The right technology for maximum efficiency (Tier 4)

## Efficient & Reliable Hydraulic System

Hydraulics are a critical aspect of a harvester functionality, so John Deere has engineered a hydraulic system that is powerful, efficient, reliable, and easy to maintain. The CH570's circuits have been enhanced to reduce power losses that will translate into fuel savings.

Top of the line piston pumps are used on the propulsion, primary extractor, basecutter, and chopper circuits to handle the heaviest cane. Nitrogen accumulators protect the lift, elevator, and topper circuits.

Only abrasion-resistant hoses are used in a clear, easy-to-maintain routing scheme. The number of hoses and fittings has also been dramatically reduced for simplicity, reliability and lower maintenance cost.

With 100% filtration and filters located inside the tank, there is minimal risk of contamination.



New cylinder functions pump is pressure compensated type that delivers oil only when required and improves system response.

## Less Down Time means More Money in your Pocket & More Value for your Investment

Service operations are easy and readily accessible with the ISO Compliant design that will save time for your technicians, whether entering the cab, changing oil, replacing filters, or checking the battery.

Ladders and handrails are located on both sides of the machine. Service platforms have non-skid surfacing and are surrounded by handrails for safe, walk-around access. The tilting cab provides quick and true access to the engine compartment.

Top-quality parts and components are used to build your harvester, so why use anything other than these same top-quality parts to keep your investment up and running? Genuine John Deere Parts are the answer to all your maintenance needs. John Deere offers superior parts service, so you achieve maximum uptime with the minimum investment.







New deep steps and better footing design.



New convenient foldable shelf facilitates access when carrying a tool box or other large miscellaneous item.



New air filter assembly is better protected and the hood is easier to grip.



Service platforms have non-skid surfacing and are surrounded by handrails for safe access.



The reversible fan automatically keeps the cooling package clean and with the New variable speed control it will maintain the engine operating at the appropriate temperature to optimize engine performance.



Access is easy with externally mounted bearings and bolt-on cradle stops with rubber shock absorber pads.



The exclusive grease cylinder facilitates elevator chain tension adjustment.



The CommandCenter™ will help you protect your equipment and quickly find solutions to possible issues by displaying alarms and diagnostics instantly.

### Engine

Model	John Deere 6090T PowerTech (Tier II)
Cylinders / Displacement	6 in line / 9.0 L
Power	251 Kw (337 Hp)
Air intake	Turbo and after-cooler (air-to-air)
Injection pump electronically controlled	
Optional engines:	
251 Kw (337 Hp) engine Tier III, or IV	
280 Kw (375 Hp) engine Tier II, III, or IV	

### Transmission

Two hydrostatic pumps providing variable speed	
Wheel machine:	0 to 24.6 km/h (15.3 mph)*
Track machine:	0 to 9.0 km/h (5.6 mph)*
*(Top speed dependent on tire and/or hydraulic system option)	

### Tank Capacities

Fuel	605 L (160 Gal)
Hydraulic oil	405 L (106 Gal)
Diesel Exhaust Fluid (DEF) (Tier 4)	54 L (14 Gal)

### Tires

Front:	Firestone 14×17.5 – 10 Ply with
Rear:	Galaxy 23.5×25 – 20 Ply Industrial w/Ag Lug
Option:	
Front: Firestone 14-17.5 (14-Ply) with	
Rear: Michelin 23.5 x 25 Industrial	

### Tracks

Sealed track chains	
457.2 mm (18 in) track shoes	
Options:	
Sealed and lubricated track chains	
41 cm (16 in), 51 cm (20 in), track pad widths	
Bent track shoes	

### Topper

Standard whole topper with gathering drums	
Maximum reach 5.2 m (17ft)	
Options:	
Shredder topper	
Extensions for standard topper	
Extended width whole topper	

### Crop Dividers & Knockdown Rollers

Manual adjustable tilt	
Options:	
Hydraulic tilt	
Side knives	
Floating crop dividers	
Crop dividers vines cutter knives	

### Basecutter

61 cm (24 in) circular basecutter discs	
Bolt-on wear plates for basecutter legs	
Options:	
56 cm (22 in) basecutter disc	
Contour basecutter height control	
Breakaway basecutter legs	

### Butlifter

Three paddle closed type	
Options:	
3 paddle open buttlifter	
4 bar open buttlifter	

### Feed Rollers

Five fixed rollers below cane mat	
Five floating rollers above cane mat	

### Chopper

Eight blade differential chopper system	
95 mm blades	
Options:	
Six blade chopper	
Eight or ten blade overlap chopper	

### Primary Extractor

Polyethylene plastic 152 cm (5 ft) hood	
Four blade fan	
Options: Duraliner steel wear ring	

### Elevator

Loading to either left or right side	
Perforated floor	
Adjustable loading flap	
Options: Elevator extensions	

### Secondary Extractor

Polyethylene plastic 90 cm (3ft) hood	
Three blade fan	
Options: Less secondary extractor	

### Comfort and Security

Pressurized cab with air conditioning and heating systems	
Front tipping cab	
Air suspension operator seat with swivel	
Training seat	
Adjustable side mirrors	
Speedometer	
Windshield wiper with water nozzle	
Side glass wipers	
Water and chemical fire extinguishers	
Anti-slip platforms in service areas	
Reverse alarm	
Engine compartment working light	
Signal and warning lights	
12 operating lights (Including headlights)	
Battery remote jump start terminals	
Am/FM Radio with auxiliary input	
Refrigerator	
Compliant with all applicable standards	

### Other Optional Features

Auxiliary LED lights	
Beacon lights	
Service tool kits	

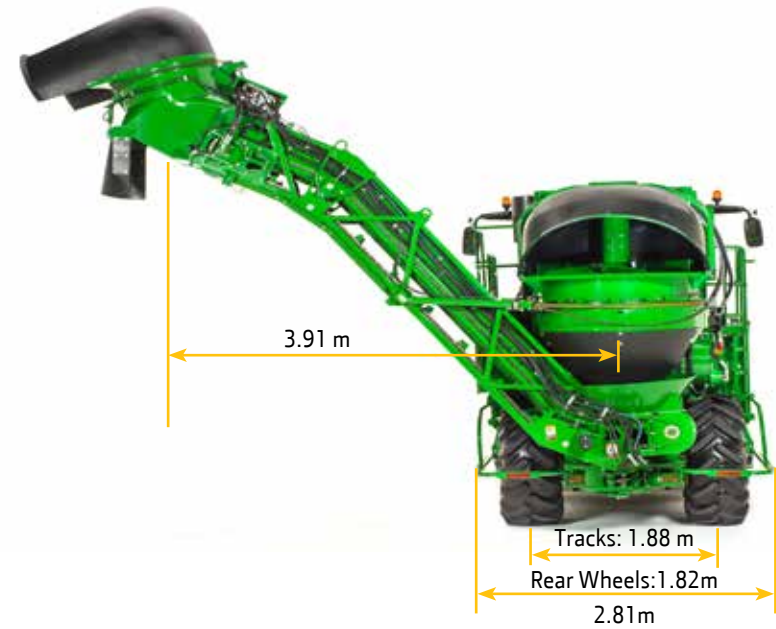
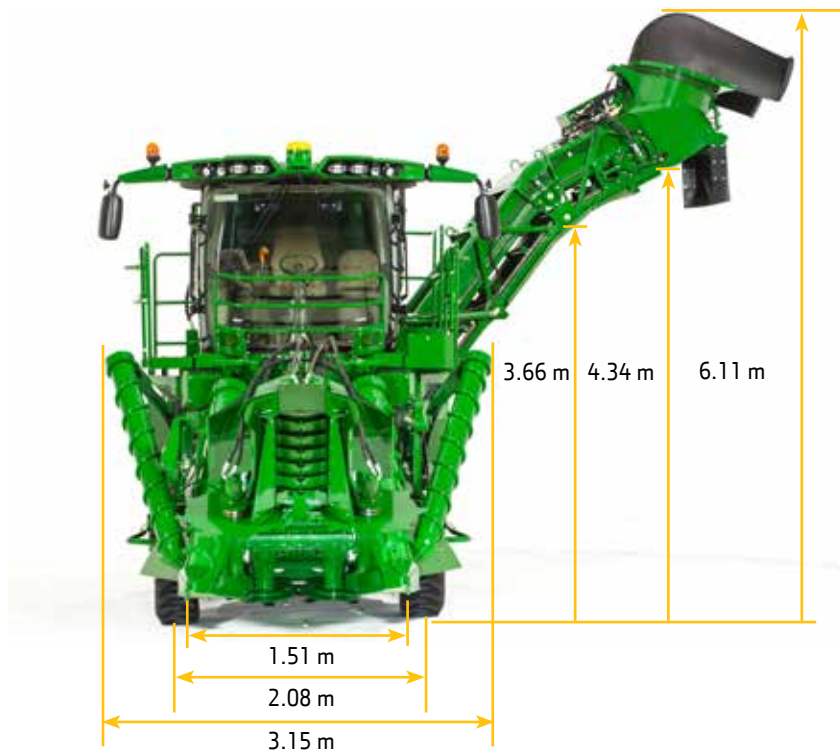
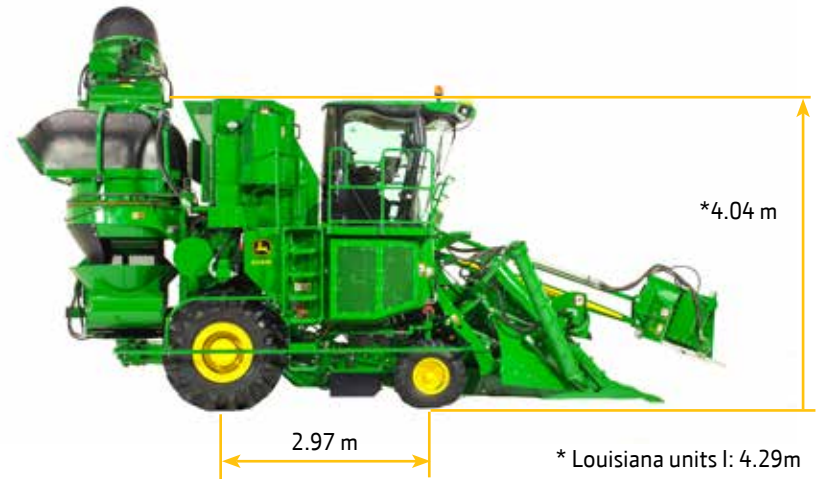



*Specifications throughout this brochure are subject to change without notification. Some photos may contain optional equipment. Some options may not be available in some markets due to legal restrictions. Revised February 2015.*  
244 Hwy 3266 · Thibodaux, LA 70301 USA  
Phone: 985.447.7285  
[www.JohnDeere.com](http://www.JohnDeere.com)